

# My Life - LIVE!

## Scenes from the Piano Man

Spencer  
 BGV - Input 23  
 Sax - Input 19  
 Bass Drum - Input 9  
 Percussion - Input 10

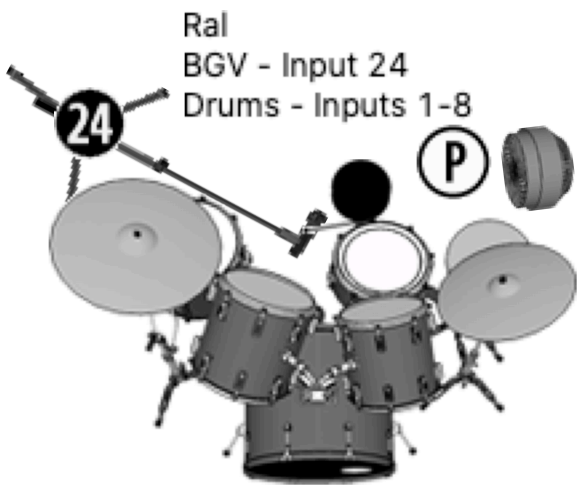
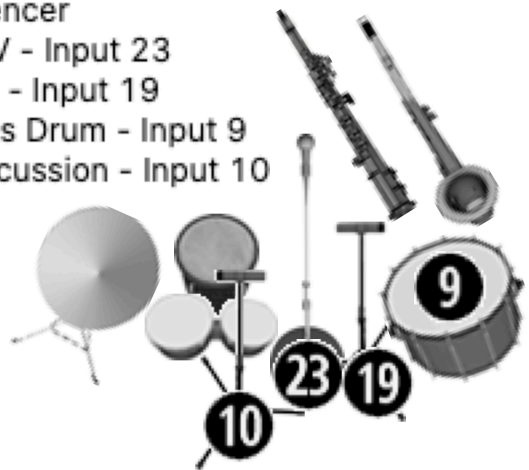

Bass Drum Mic  
 Provided / Mounted

Ryan  
 BGV - Input 22  
 Ac GTR - Input 12 (DI)  
 EL GTR - Inputs 13/14

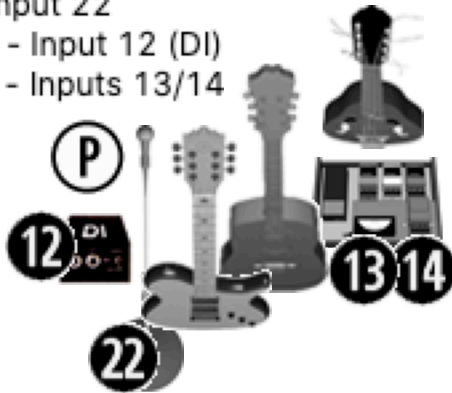

Ryne  
 BGV - Input 20  
 Bass Gtr - Input 11

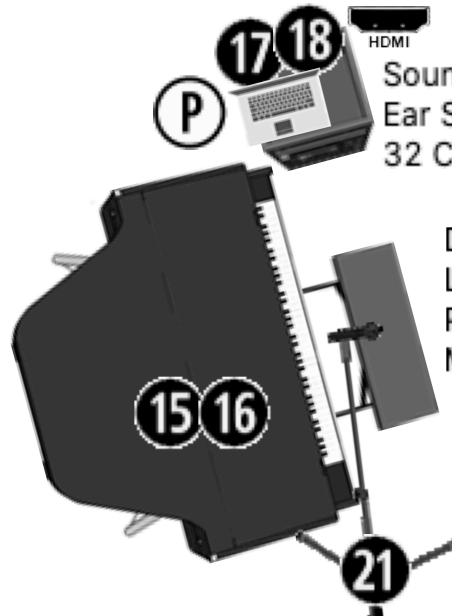
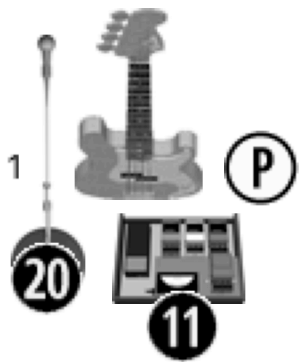

Dan  
 LV - Input 21  
 Piano L/R - Inputs 15/16  
 MIX L/R - Inputs 17/18

Soundcraft UI24r  
 Ear Splitter Snake  
 32 Channel

POWER NEEDED = (P)

- 1. Kick
- 2. Snare
- 3. Hi Hat
- 4. Tom 1
- 5. Tom 2
- 6. Tom 3
- 7. OH L (Larger Rooms)
- 8. OH R (Larger Rooms)
- 9. Percussion Bass Drum
- 10. Bongos / Congos

- 11. BASS
- 12. AC GTR (DI)
- 13. EL GTR L
- 14. EL GTR R
- 15. PIANO L
- 16. PIANO R
- 17. MIX L
- 18. MIX R
- 19. SAX

- 20. BGV (RYNE)
  - 21. LEAD VOCAL (DAN)
  - 22. BGV (RYAN)
  - 23. BGV (SPENCER)
  - 24. BGV (RAL)
- Inputs 13 & 14 are stereo pair.  
 (EL GTR) Hard Left / Right
- Inputs 15 & 16 are stereo pair.  
 (PIANO) Hard Left / Right

Inputs 17 & 18 are stereo pair.  
 (MIX) Hard Left / Right

Tracks mastered to -3db. Little effort needed. Just keep the "MIX BGV's" (tracks) slightly under the LV - Mix to taste.

HDMI INPUT FOR VIDEO ELEMENTS (IF AVAILABLE)